

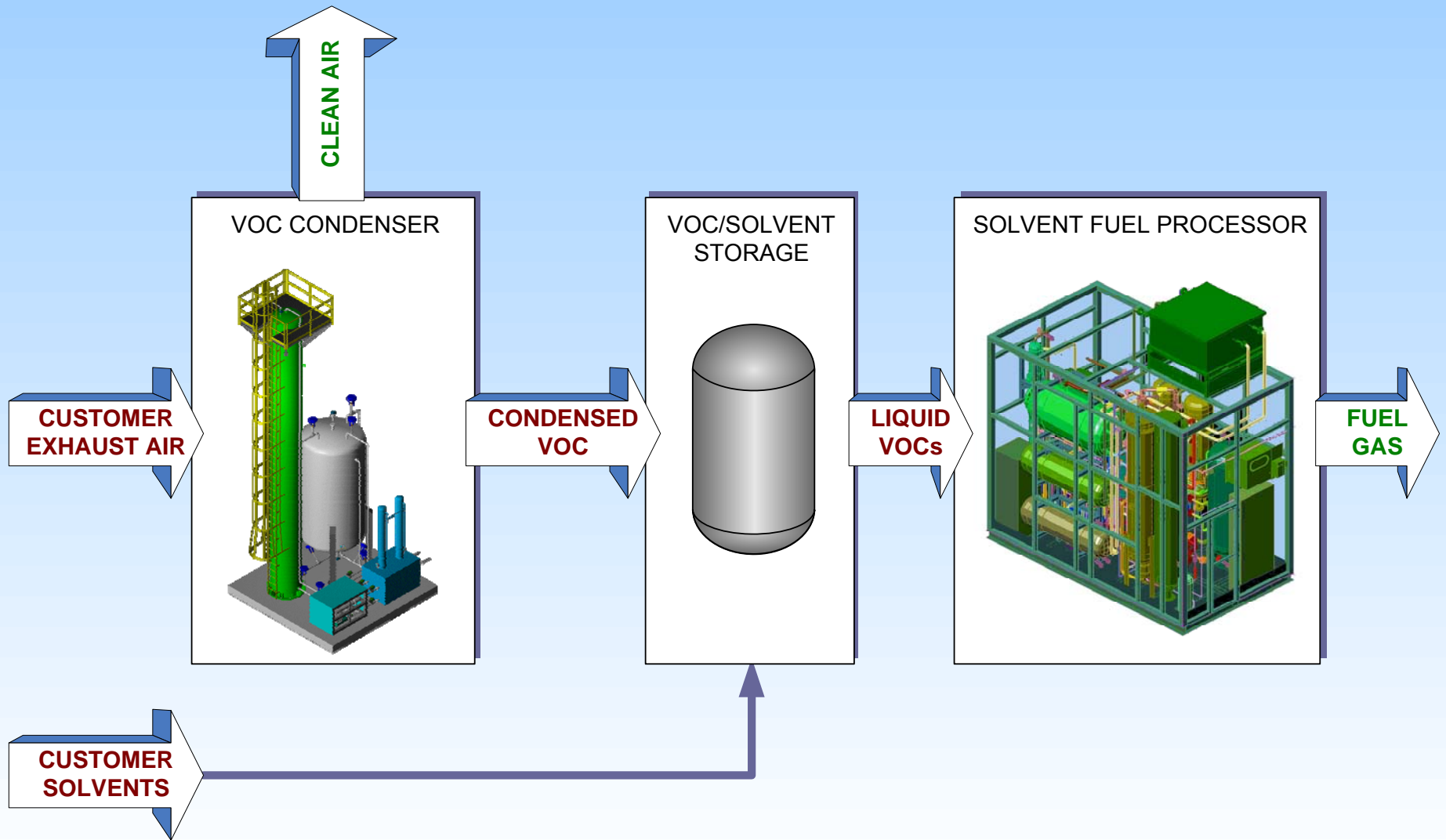

from ARENCIBIA ASSOCIATES, INC.

Process Overview: Building Blocks



from ARENCIBIA ASSOCIATES, INC.

VOC Condenser

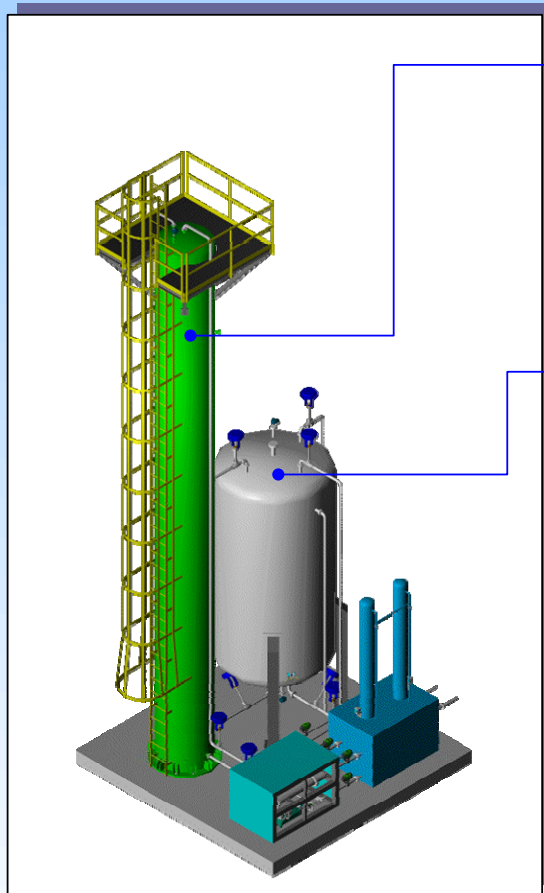

Cryogenic “Cold-Box”

- ▶ 99.9%+ removal efficiency of VOCs
- ▶ Operating cost depends on inlet VOC concentration and desired exhaust VOC concentration
- ▶ No issue with entrained water or dust
- ▶ Well suited to batch operations (unlike RTO/TOX)

Liquid N2 (LIN) Refrigerant

- ▶ Once-through use
- ▶ Optional closed loop re-liquefier



ONE OF SEVERAL ARENCIBIA “COLD BOX” CONDENSERS IN OPERATION



from ARENCIBIA ASSOCIATES, INC.

Solvent Fuel Processor

Liquid Fuel Converter

- ▶ Proprietary Heat-integrated Catalytic Unit
- ▶ Conversion options for H₂, Syngas or SNG production
- ▶ Generate 1.1-1.5 kWh/lb-VOC recovered
- ▶ Handles mixed and variable solvent feeds

On-line Analysis & Composition Control

Heat Integration

- ▶ Cold-start heaters for stand-alone operation
- ▶ Steady-state net heat generation

PLC/HMI – Based Controls

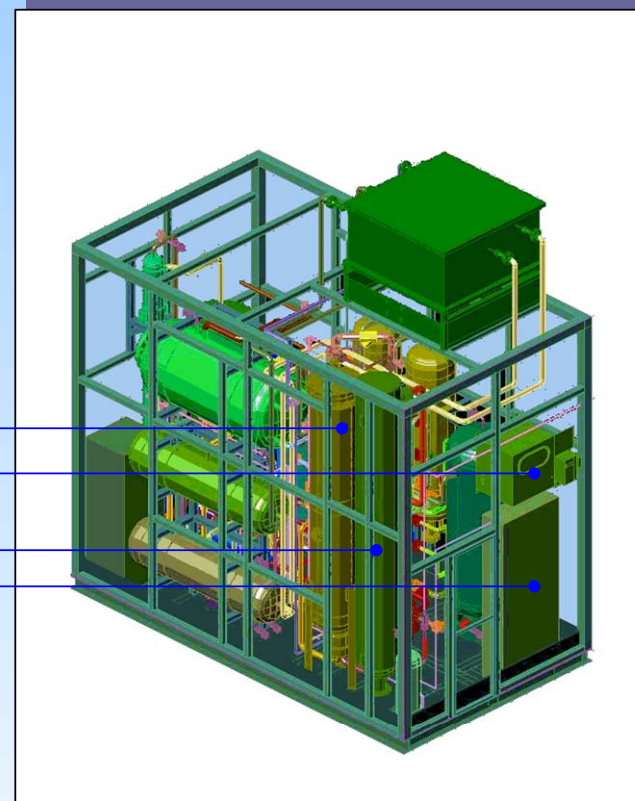

300 KW SOLVENT FUEL PROCESSOR AT FORD MOTOR CO



from ARENCIBIA ASSOCIATES, INC.

Fuel Processor Module Concept

- ▶ Common utilities are sized for the full system capacity
- ▶ VOC Fuel Processing is done using multiplexed modules, each of which processes approximately 200 lb/hr of VOC
- ▶ Module configuration reduces the risk of contamination for multi-source VOC streams and allows module optimization based on VOC source types

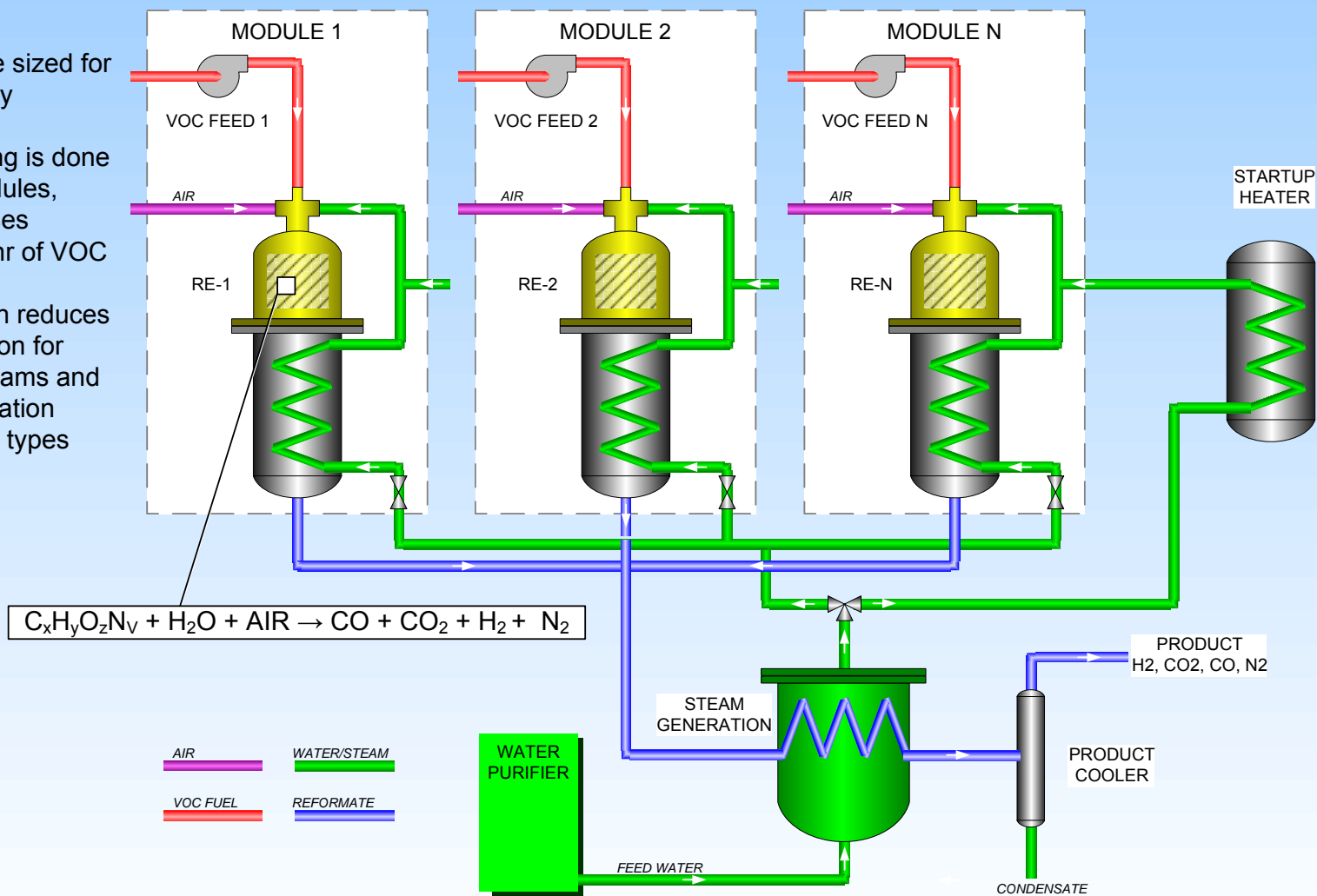

from ARENCIBIA ASSOCIATES, INC.

Product Options

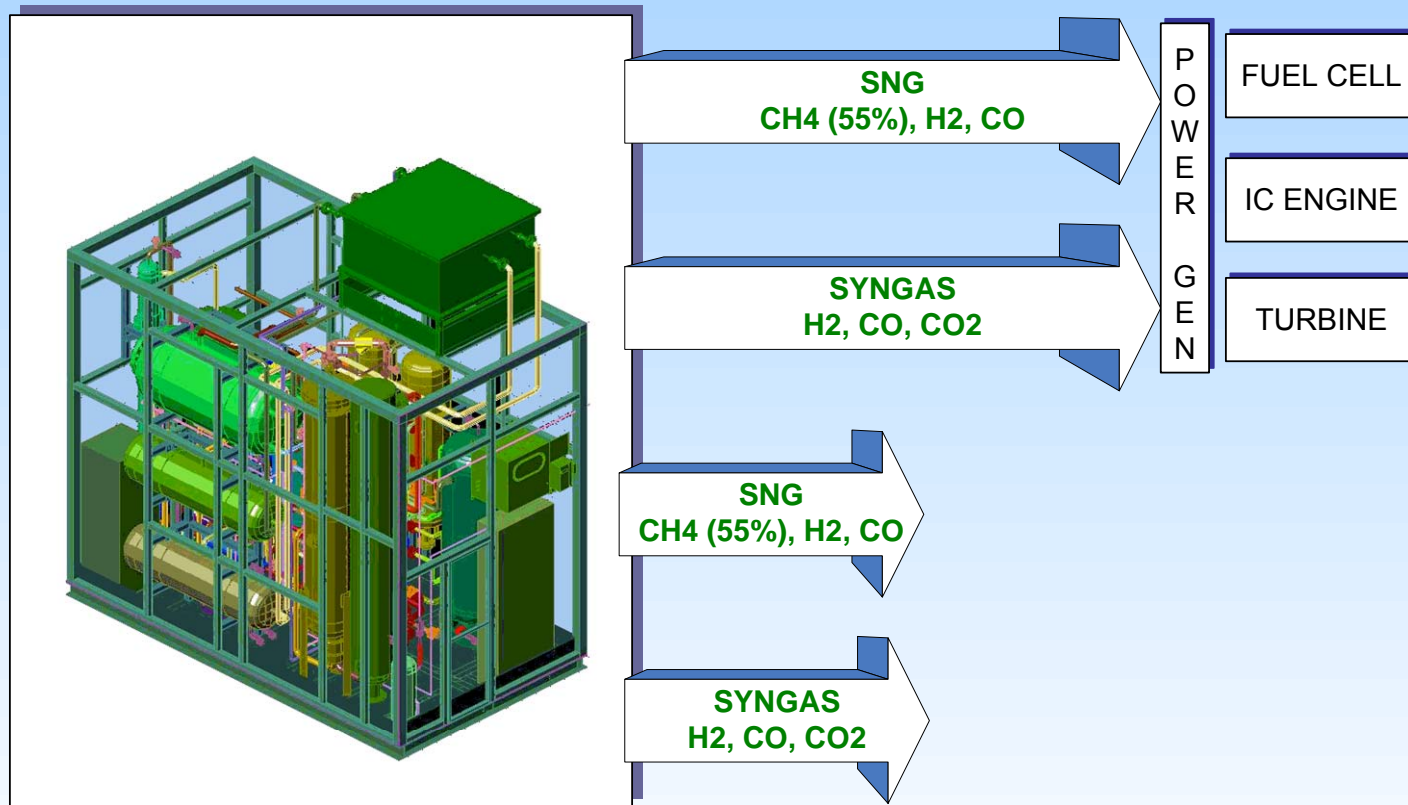

from ARENCIBIA ASSOCIATES, INC.

Product Options: Relative Capital

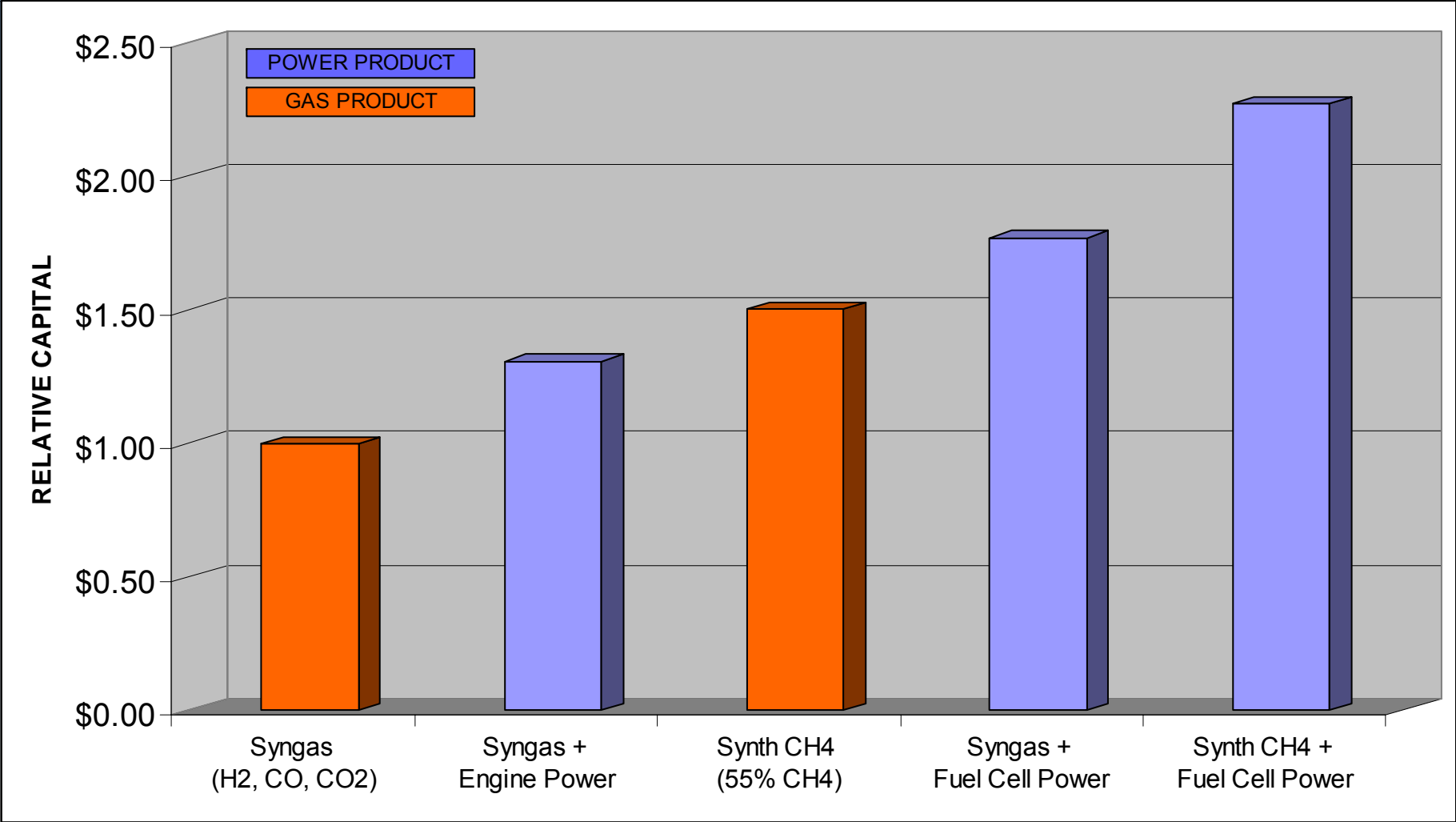

Case Study: 100,000 Gallons Waste Solvent

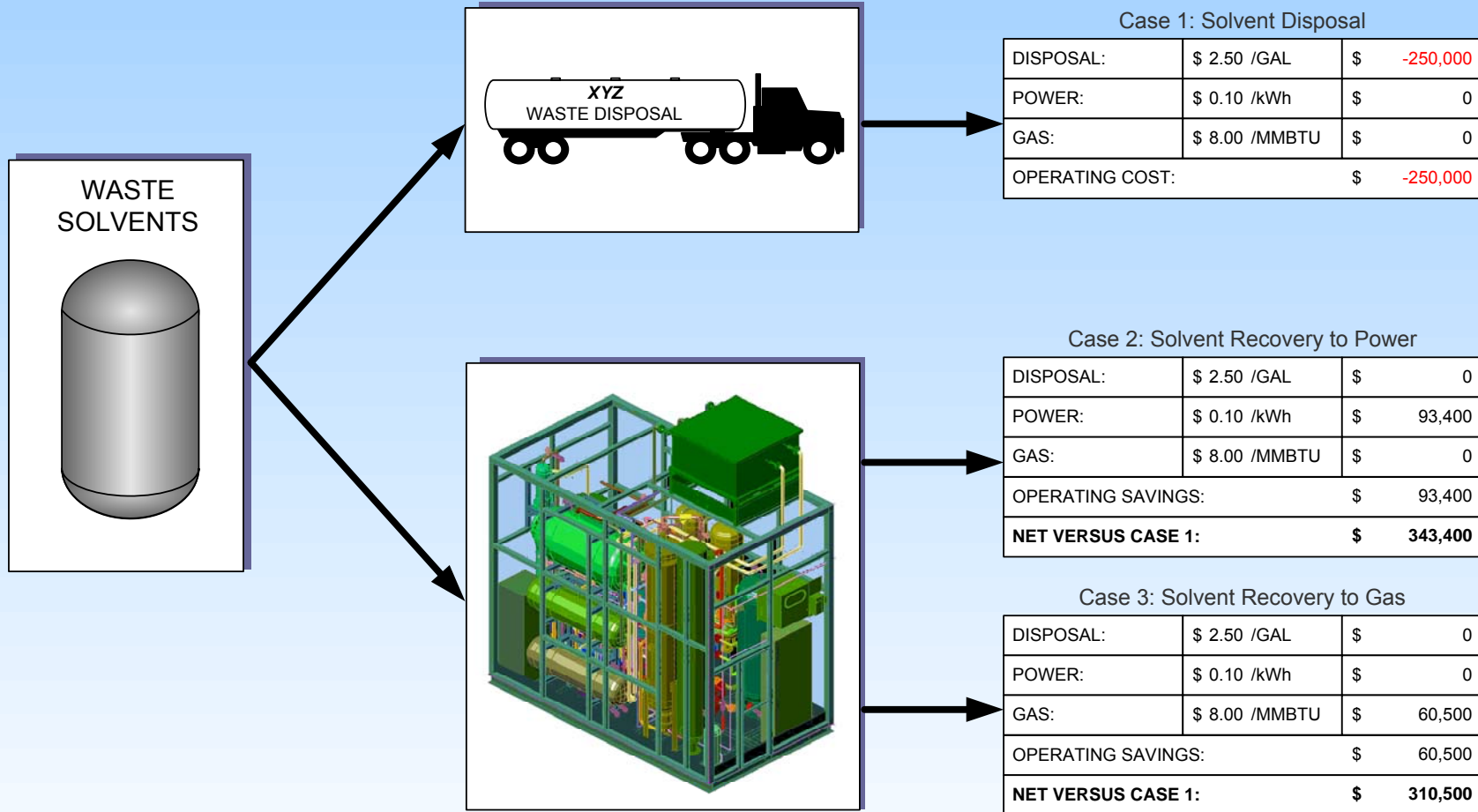

from ARENCIBIA ASSOCIATES, INC.